

SunSDR2DX Output voltage spikes investigation, Max output power, Test Report

By Ivan De Cesaris IZ0JNY/HB9ETO

Iss. 2, Dec. 21st 2021

Fig. 1: The SunSDR2 DX, front view



Fig. 2: The SunSDR2 DX, rear view



Introduction

Some users have had negative experiences with driving LDMOS amplifiers via their rigs; few transceivers are suspected of generating voltage spikes, which, even for a short time, greatly exceed the set output power, damaging the LDMOS of the linear power amplifiers. This scope of this test report is to analyze the behavior of the output voltage of SunSDR2 DX transceiver to understand if this problem is present.

Another additional test was done, to measure the maximum output power in different bands.

SunSDR2D DX general description

SunSDR2 DX is a direct sampling 100-watt SDR transceiver developed. It covers all HF bands plus 50 MHz and 144 MHz VHF bands with a general coverage receiver. It combines high performance and 100 watt transmit power in a small package with a LAN

interface for maximum flexibility. Remote control over network connections provide a full SDR experience using the Expert Remote System.

SunSDR2 DX Main Capabilities

- Independent RX path based on DDC (Direct Down-Conversion) architecture
- Independent TX path based on DUC (Direct Up-Conversion) architecture
- Output power: 100W on HF, 50W on 6M and 8W on 2M
- 2 software RXs + SubRX for each of them (4 slices total) + independent wideband Bandscope up to 80 MHz
- Remote control operation, using it, you connect PTT and CW-key to the E-Coder panel. Microphone and E-Coder are connected to the remotely set up PC
- TCI interface for seamless connection with third-party software like SDC (with its own Skimmer), LogHX, SWISSLOG and RUMlog, more are coming
- Professional TX processing module provides the most advanced tuning capability for voice operation
- ExtCTRL connector to control external devices with 8 powerful keys with open collector
- ALC connector for external power amplifiers*
- Supports use of VHF transverters**
- An opportunity to use the transceiver as a signal generator via DAC OUT connector (SMA connector)
- An opportunity to use external filters in the middle of the RF path, using ADC IN and RX OUT (SMA connector)
- Minimal delay in CW mode (about 10 ms)
- Input for external 10 MHz reference oscillator
- An opportunity to use the transceiver in SO2V mode
- Full duplex or half duplex modes***
- Antenna switch with 2 HF antenna connectors and separate VHF antenna connector (Mini UHF connectors)
- Internal power-meter for HF and VHF bands and SWR-meter for HF band
- Ethernet LAN interface provides a fast and reliable connection to PC
- 100 watt transmit power on HF, 80 watt on 50 MHz!
- ATU connector for AAT-100 automatic antenna tuner option
- External Fan connector
- External fan (included)
- HPF for VHF (100 MHz) to eliminate strong out-of-band stations coming from HF
- LPF for HF (70 MHz) to eliminate strong out-of-band stations coming from VHF
- Improved VHF LNA (PGA103+ chip)

- High-performance built-in stereo audio codec 24 bit with 114 dB dynamic range
- Anderson Powerpole power connector
- Ground connector added
- Sturdy DIP-type ExtCtrl connector
- Opportunity to use the transceiver as a signal generator via DAC OUT connector (SMA connector)
- Opportunity to use external filters in the middle of the RF path, using ADC IN and RX OUT (SMA connector)
- Minimal delay in CW mode (about 10 ms)
- Input for external 10 MHz reference oscillator
- Opportunity to use the transceiver in SO2V mode
- Full duplex or half duplex modes***
- Antenna switch with 2 HF antenna connectors and separate VHF antenna connector (Mini UHF connectors)
- Internal power-meter for HF and VHF bands and SWR-meter for HF band
- Ethernet LAN interface provides a fast and reliable connection to PC

** ** *** These functions are supported by the transceiver's hardware, but is not implemented in the ExpertSDR2 software. They will be supported in the future ExpertSDR2 software releases.*

Fig. 3: The SunSDR2 DX Architecture

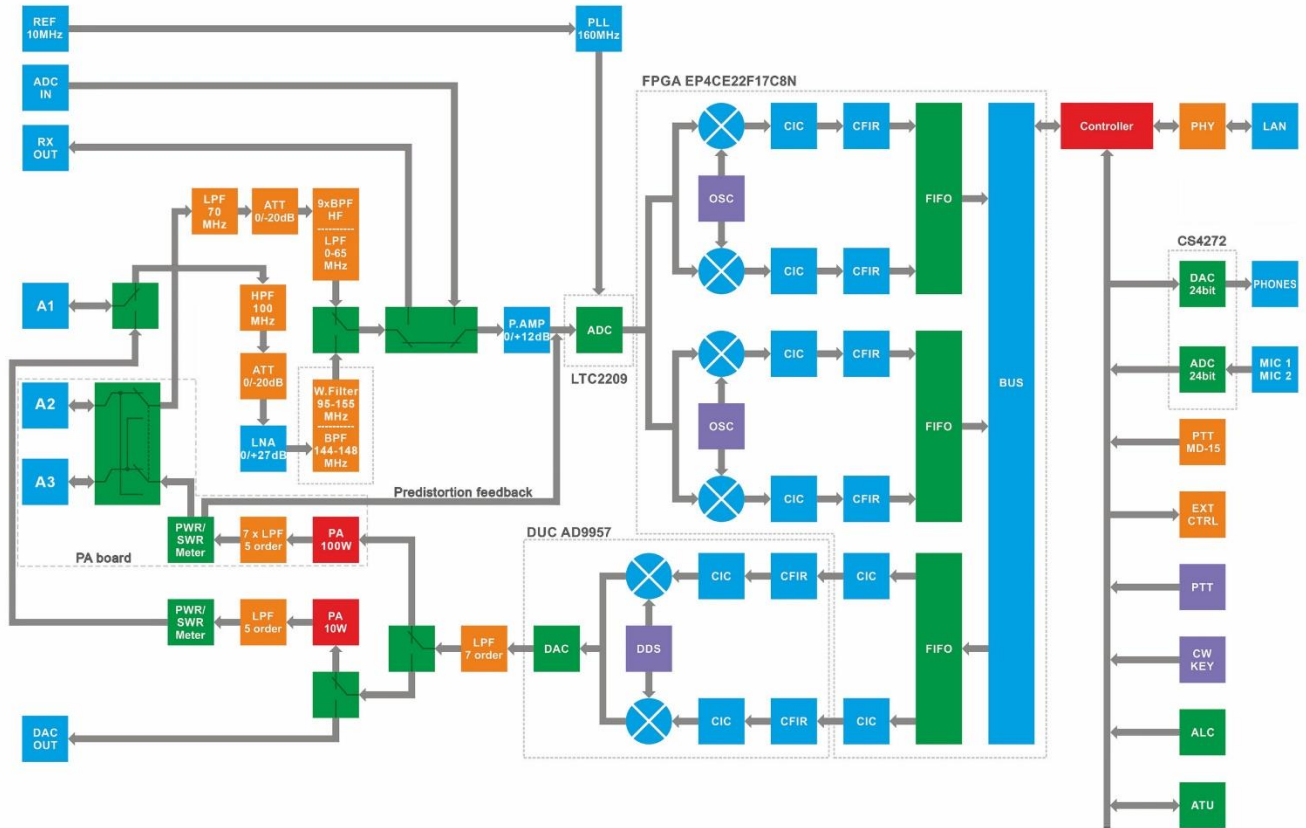

ExpertSDR2 Software

The ExpertSDR2 software package is used to control the SDR transceiver. In receiving mode the software provides two independent receiving channels with up to 312 kHz bandwidth. Each receiver has its own sub receiver. ExpertSDR2 runs under Windows XP/7/8/10 x32 or x64, Linux Ubuntu x64 and MacOS (MacOS currently beta). Minimum hardware requirement Intel Core i3 1.6GHz or higher, video card supporting OpenGL 1.5 and RAM 256 MB or more.

An alpha version 0.10.0 of ExpertSDR3 software is already available for download on the official website of Expert Electronics: <https://eesdr.com/en/software-en/expertsdr3-en> . Video card supporting OpenGL or Vulkan.

Fig. 4: ESDR2 software for Windows

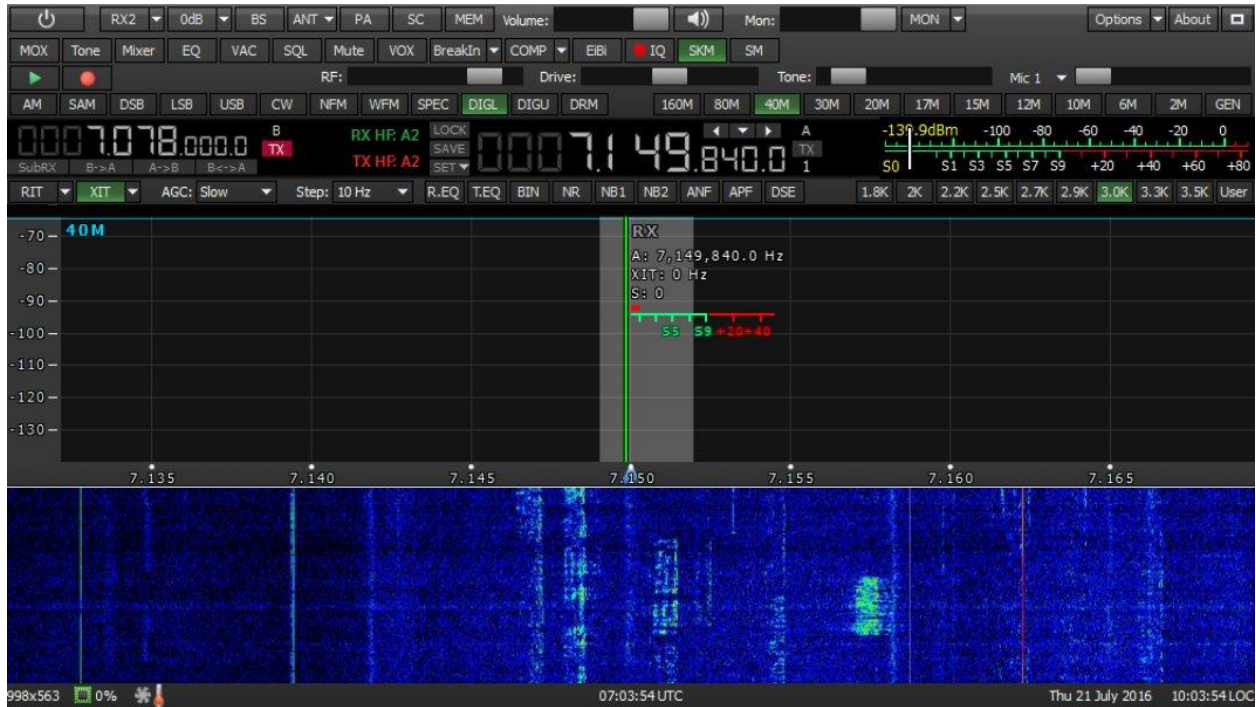

SunSDR2 DX Specifications

RF ADC, bit @ MHz	16 @ 160
ADC type	LTC2209
RX Frequency range, MHz	0.1...65; 95...155
Independent software receivers	2 + 2 SubRX
Sample rate, kHz @ bit	39; 78; 156; 312 @ 24
Bandscope, MHz	80
RX HF filters, MHz	LPF: 65 or 9 x BPF + constant LPF: 70
RX VHF filters, MHz	WideRX: 95-155 or SAW filter for 2M: 144-148 + constant HPF: 100
BDR on HF, dB	130
BDR on VHF, dB	129
Sensitivity, uV	0.2
ATT/Preamp, dB	-20; -10; 0; +10

VHF LNA, dB	27
	9 x HF octave band pass filters: 160M: 0-2.5 MHz (Chebyshev I – 7 Order) 80M: 2.5-4 MHz (Chebyshev I – 3 Order) 60M: 4-6 MHz (Chebyshev I – 3 Order) 40M: 6-7.3 MHz (Chebyshev I – 3 Order) 30M: 7.3-12 MHz (Chebyshev I – 3 Order) 20M: 12-14.5 MHz (Chebyshev I – 3 Order) 17-15M: 14.5-21.5 MHz (Chebyshev I – 3 Order) 12-10M: 21.5-30 MHz (Chebyshev I – 3 Order) 6M: 30-65 MHz (Chebyshev I – 3 Order) Wide filters for entire Nyquist zones 0-65 MHz and 95-155 MHz
Band Pass Filters	
RF DAC, bit @ MHz	14 @ 640
TX Frequency range, M	All amateur bands 160m to 6m and 2m
Output power on HF, W	100
Output power on 6M, W	Up to 80
Output power on VHF, W	7 (up to 8)
TX IMD3 HF / VHF, dB	37 / 30
	8 x LPF: 160M: (Eleptic – 5 order) 80M: (Eleptic – 5 order) 60-40M: (Eleptic – 5 order) 30-20M: (Eleptic – 5 order) 17-15M: (Eleptic – 5 order) 12-10M: (Eleptic – 5 order) 6M: (Eleptic – 5 order) 2M: (Eleptic – 5 order)
TX Filters	
Local oscillator TCXO, MHz +/- ppm	20 +/- 0.5
External 10 MHz oscillator input +	
Built-in audio codec, bit	24
RF input/output	2HF, 1VHF (Mini_UHF) ADC IN, DAC OUT (SMA)
PC interface	LAN 100 Mbit
DC voltage range in RX/TX, V	8 – 14.8 / 10 – 14.8
Recommended DC voltage, V	13.8
Current consumption RX/TX, A	1.2 / 24
Power consumption RX/TX, W	16.5 / 330
Operating temperature, °C/°F	0 to +50 / +32 to +122

**Dimensions L x W x H,
cm/inches**

19.0 x 17.0 x 8.0/ 7.48 x 6.69 x 3.14

Weight, kg/lbs

1.8/ 3.96

Instruments setup for output voltage spikes measurements.

The tests were carried out using a SunSDR2DX transceiver connected via a cable of about 20cm of the RG58 type, via UHF-259 connectors to a dummy load MFJ-264, capable of dissipating 1.5kW for 10 minutes.

To measure the output voltage we used a Tektronix MSO2012B oscilloscope, with a 10:1 probe connected directly inside of the MFJ-264 dummy load, as shown in Fig. 5.

Fig. 5: probe positioning

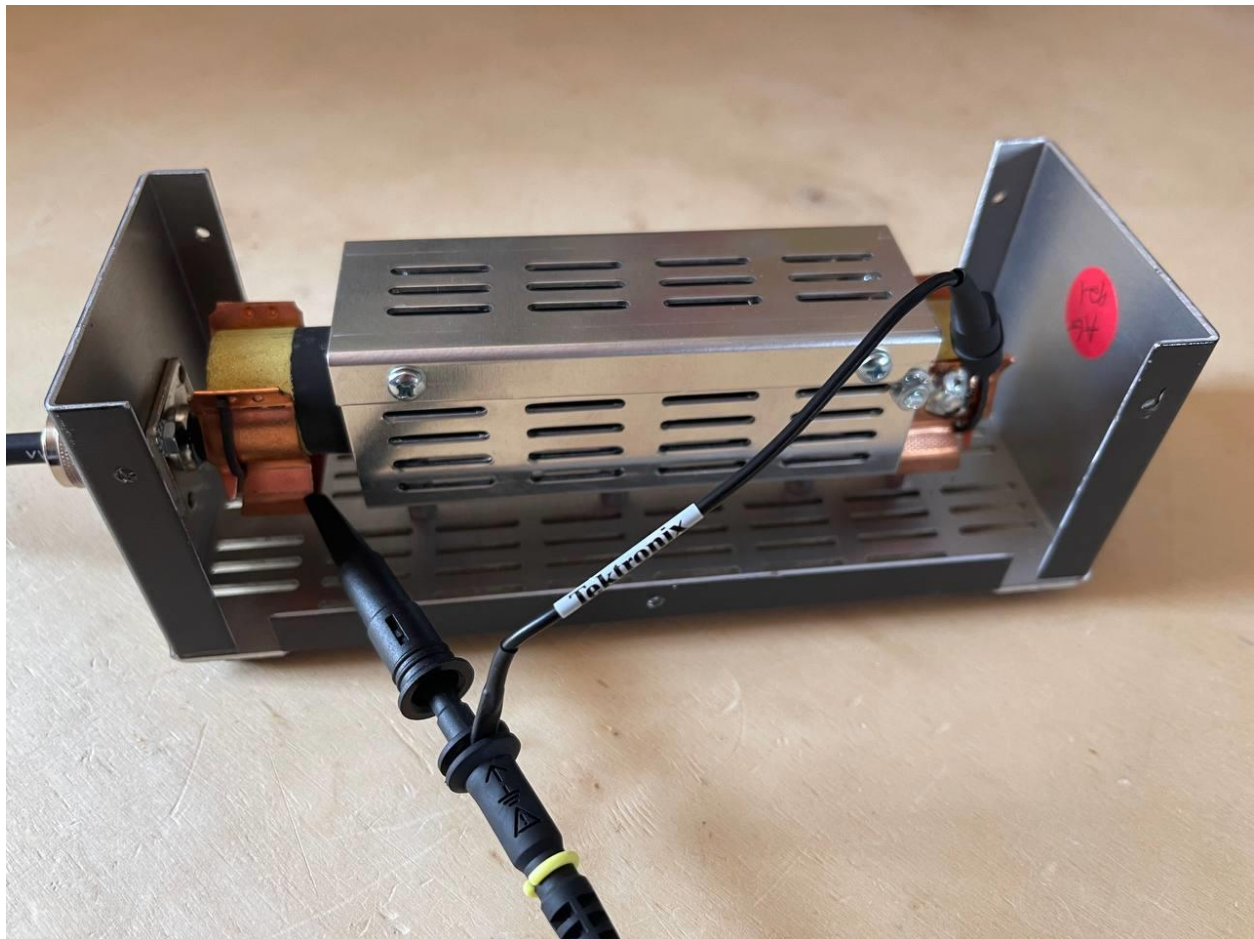

SSB test

This test was made using a PC equipped with an external sound card, brand Focusrite model 2i2 2nd generation, and a Marantz microphone connected on it.

Fig. 6: main carrier @3.770 MHz, LSB, Drive slider 25%

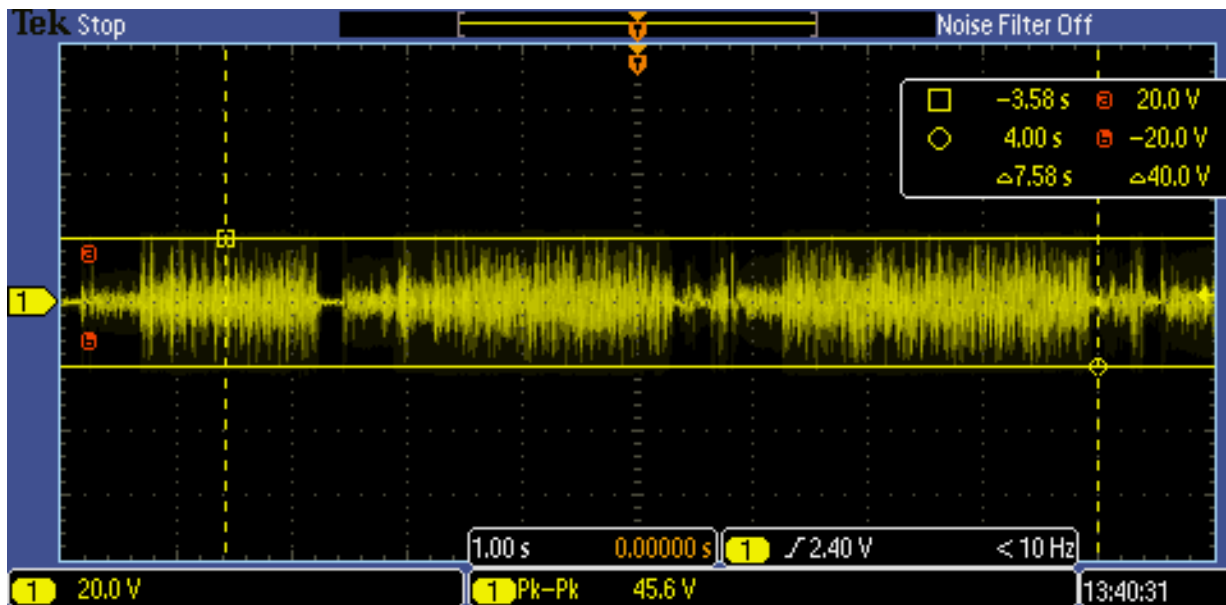

We set the Drive slider to ESDR2 at 25%, and modulated to the microphone. A peak-to-peak value of 45.6V is measured, equal to approximately 5W of output. The main carrier is at 3.770 MHz.

Fig. 7: main carrier @3.770 MHz, LSB, Drive slider 30%

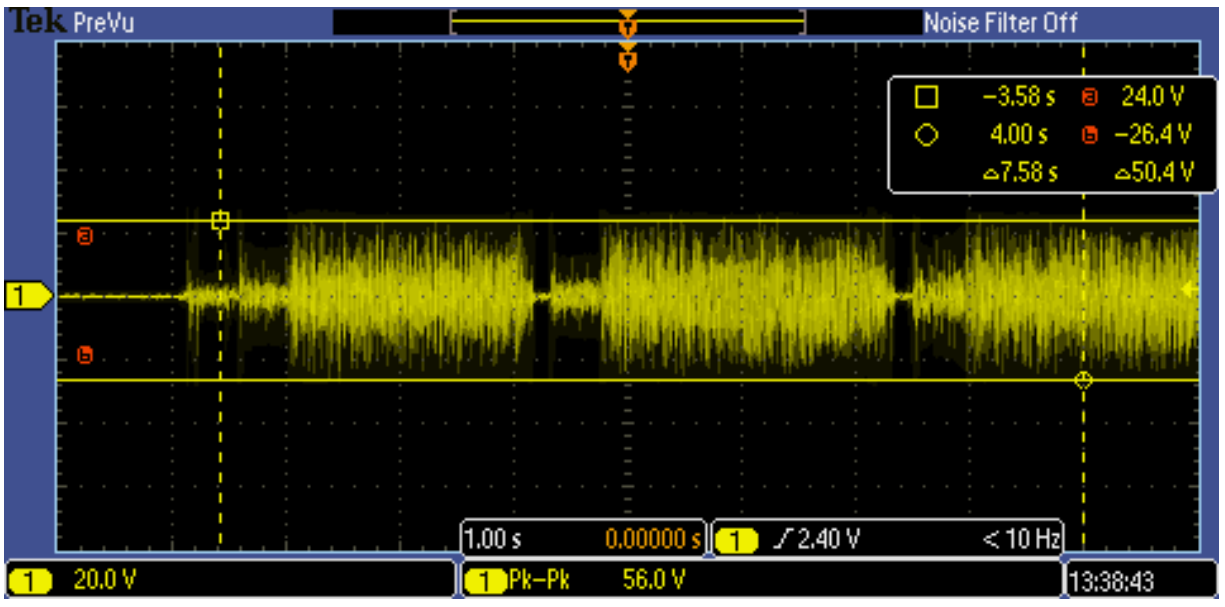

We set the Drive slider to ESDR2 at 30%, and modulated to the microphone. A peak-to-peak value of 56V is measured, equal to approximately 7.8W of output. The main carrier is at 3.770 MHz.

Fig. 8: main carrier @3.770 MHz, LSB, Drive slider 50%

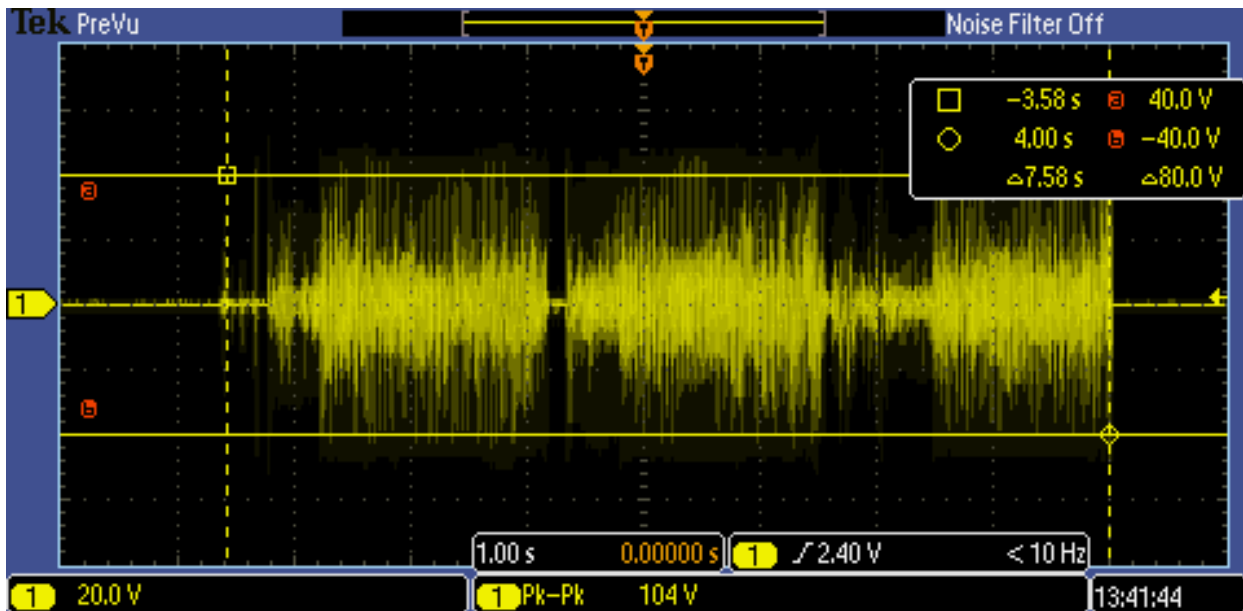

We set the Drive slider to ESDR2 at 50%, and modulated to the microphone. A peak-to-peak value of 106V is measured, equal to approximately 28W of output. The main carrier is at 3.770 MHz.

Fig. 9: main carrier @14.200 MHz, USB, Drive slider 25%

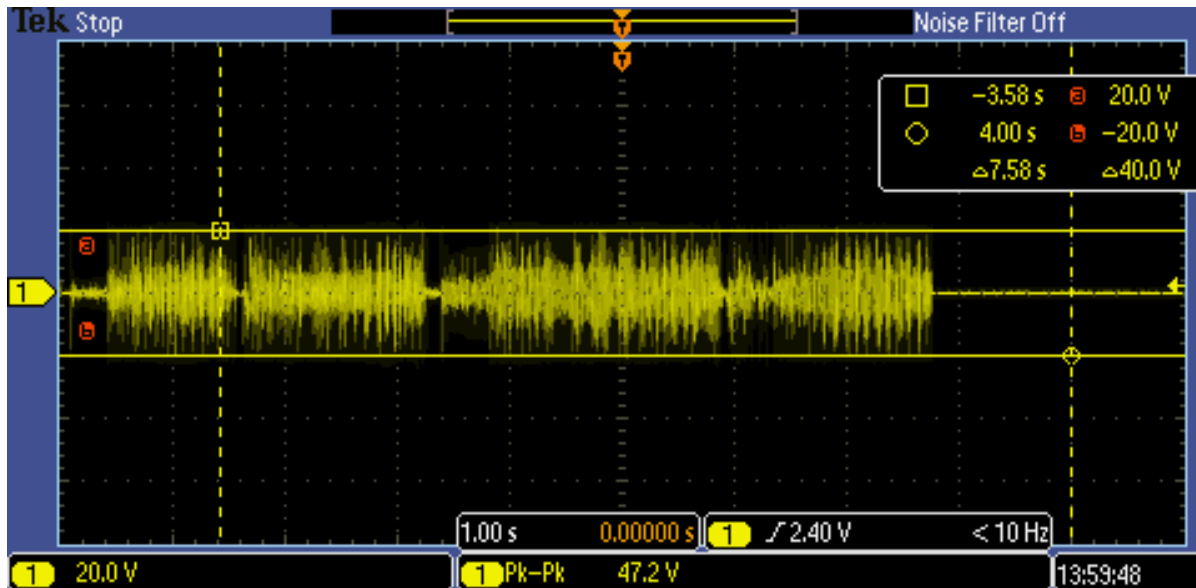

We set the Drive slider to ESDR2 at 25%, and modulated to the microphone. A peak-to-peak value of 47.2V is measured, equal to approximately 5.5W of output. The main carrier is at 14.200 MHz.

Fig. 10: main carrier @14.200 MHz, USB, Drive slider 30%

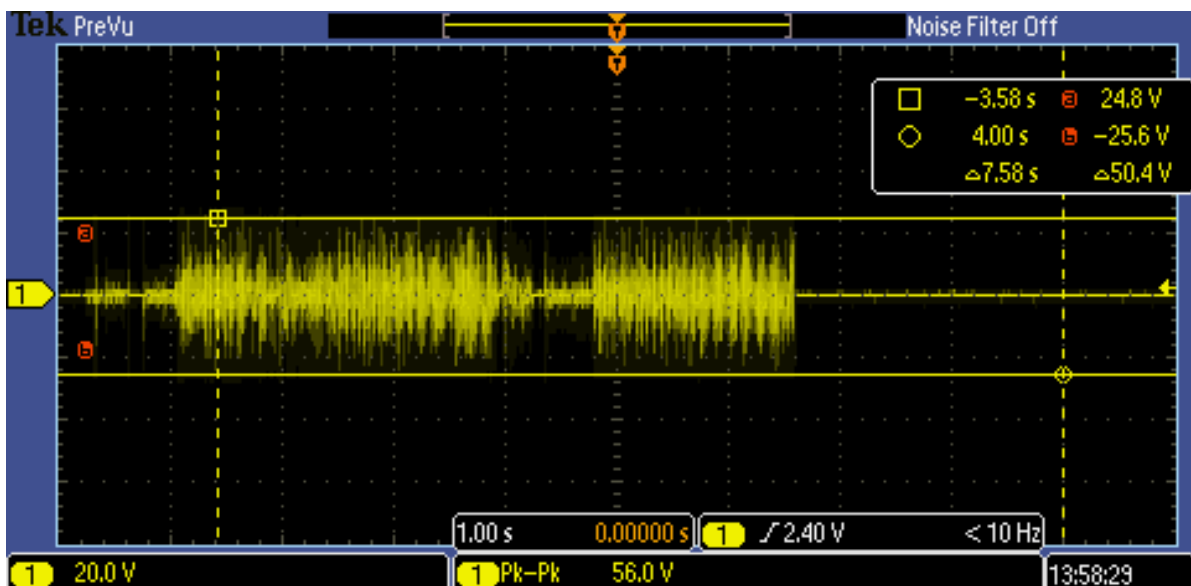

We set the Drive slider to ESDR2 at 30%, and modulated to the microphone. A peak-to-peak value of 56V is measured, equal to approximately 7.8W of output. The main carrier is at 14.200 MHz.

Fig. 11: main carrier @14.200 MHz, USB, Drive slider 50%

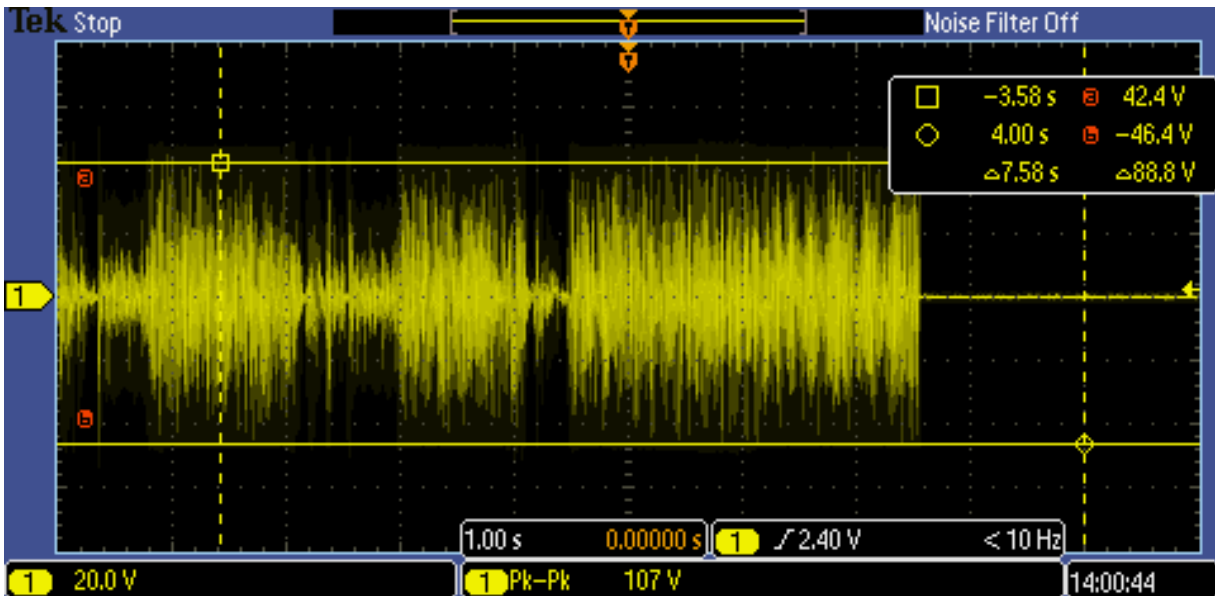

We set the Drive slider to ESDR2 at 30%, and modulated to the microphone. A peak-to-peak value of 107V is measured, equal to approximately 28.6W of output. The main carrier is at 14.200 MHz.

Fig. 11: main carrier @28.850 MHz, USB, Drive slider 25%

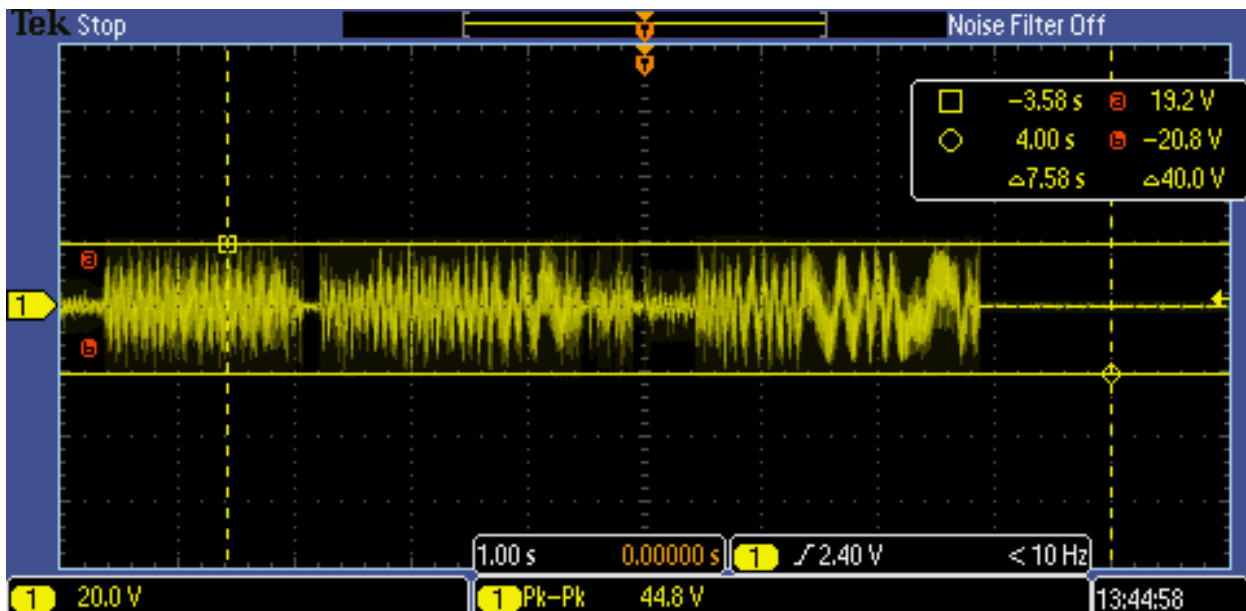

We set the Drive slider to ESDR2 at 25%, and modulated to the microphone. A peak-to-peak value of 44.8V is measured, equal to approximately 4.8W of output. The main carrier is at 28.850 MHz.

Fig. 11: main carrier @28.850 MHz, USB, Drive slider 30%

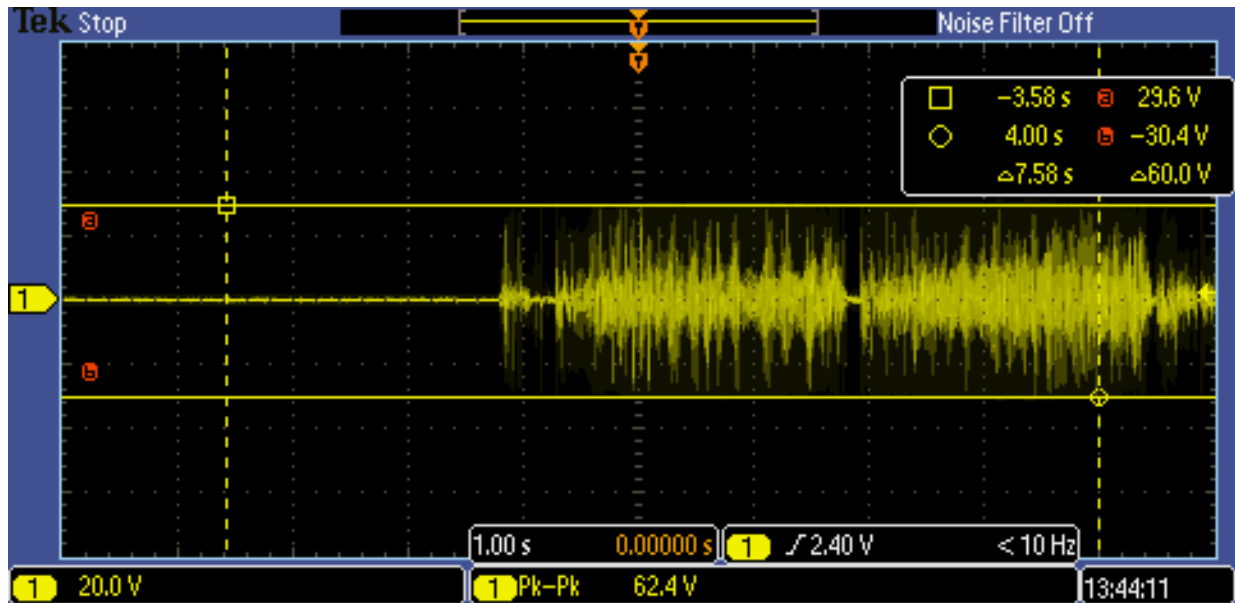

We set the Drive slider to ESDR2 at 30%, and modulated to the microphone. A peak-to-peak value of 66.4V is measured, equal to approximately 11W of output. The main carrier is at 28.850 MHz.

Fig. 12: main carrier @28.850 MHz, USB, Drive slider 50%

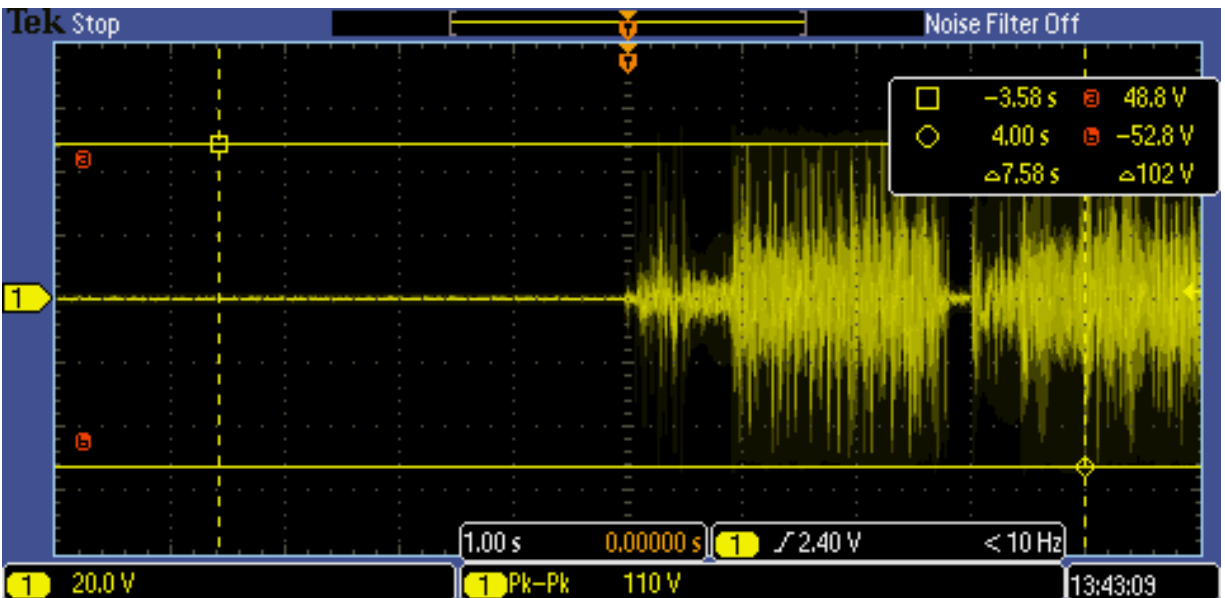

We set the Drive slider to ESDR2 at 50%, and modulated to the microphone. A peak-to-peak value of 110V is measured, equal to approximately 30W of output. The main carrier is at 28.850 MHz.

SSB test, conclusion.

As you can see from each measurements, there are no spikes with a voltage higher than the set one, corresponding to the horizontal cursors in the scope snapshots. **No spikes was detect, and no voltage was exceeding the limit set in ESDR2.0 Drive slider.**

The tests was performed in different bands, 80m, 20m, 10m main carrier SSB transmission. The value of output power is approximated cause we assume a perfect sine wave, while in SSB the modulated side band is not perfectly a sine wave.

The small waves that in some cases precedes the main carrier, is to be attributed to the rebound of the mechanical push button of the PTT.

Digital mode – FT8

After having carried out the tests in SSB, we proceeded to test the transmission in one of the most used digital modes, the FT8. We generated the signal using JTDX software, v2.2.156. Transmission at 14.074MHz.

Fig. 13: FT8, Drive 30%

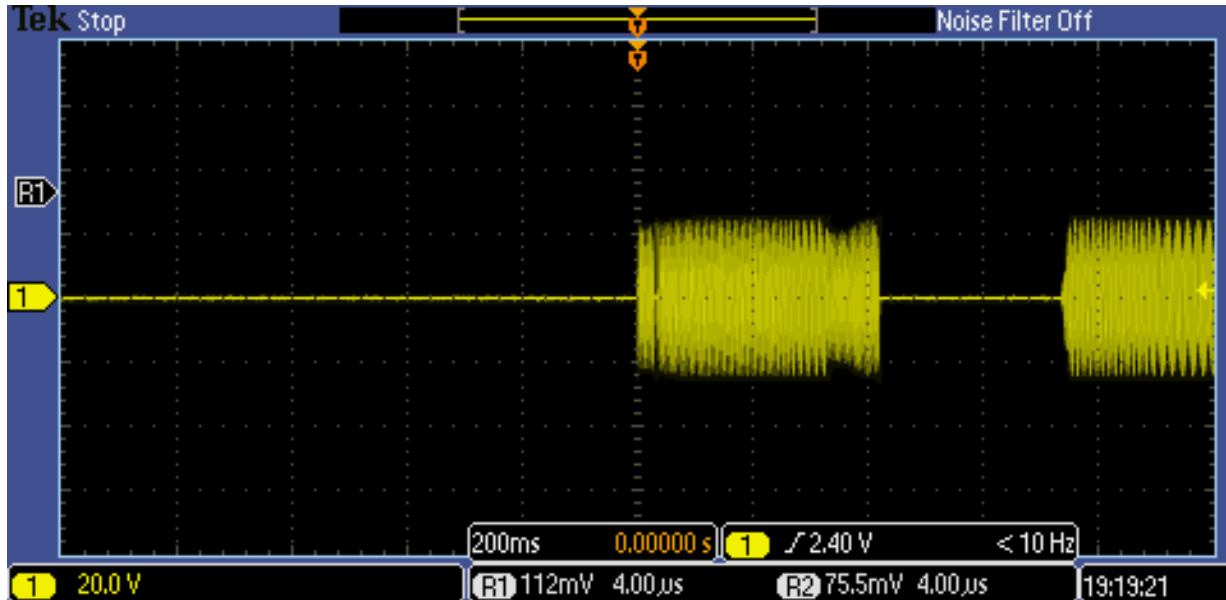

Fig. 14: FT8, Drive 40%

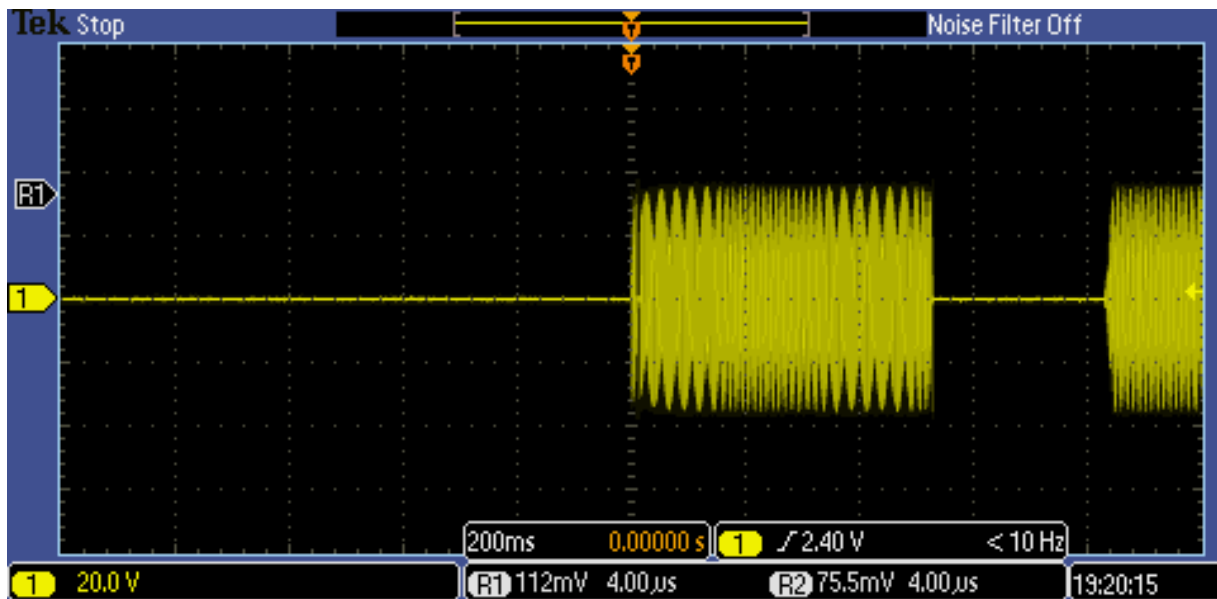

Fig. 15: FT8, Drive 60%

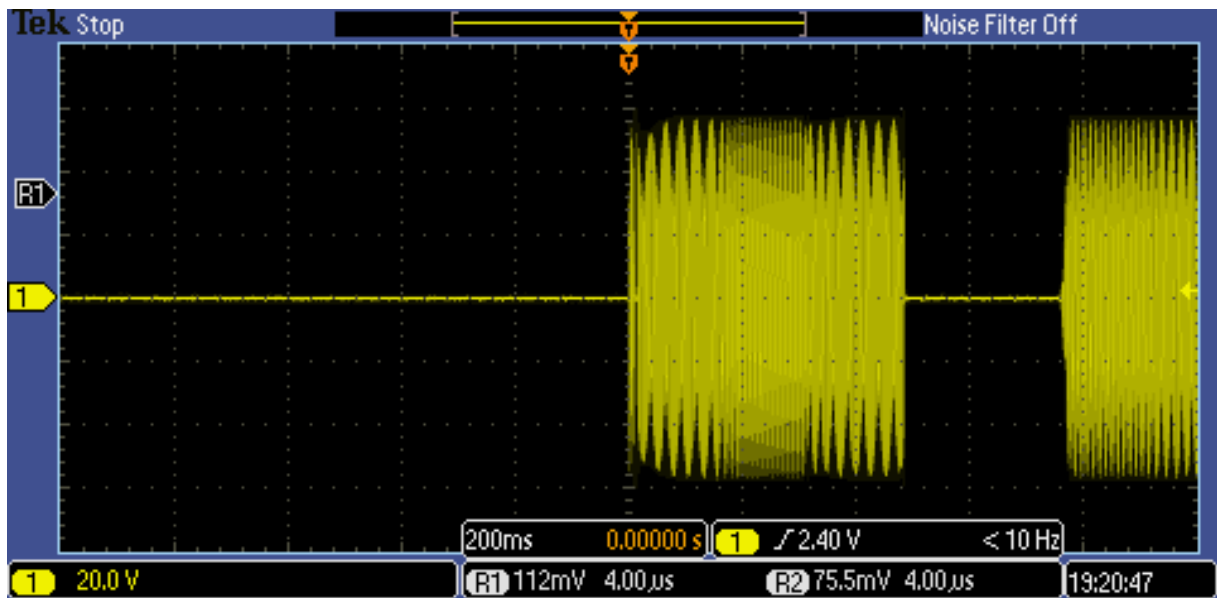
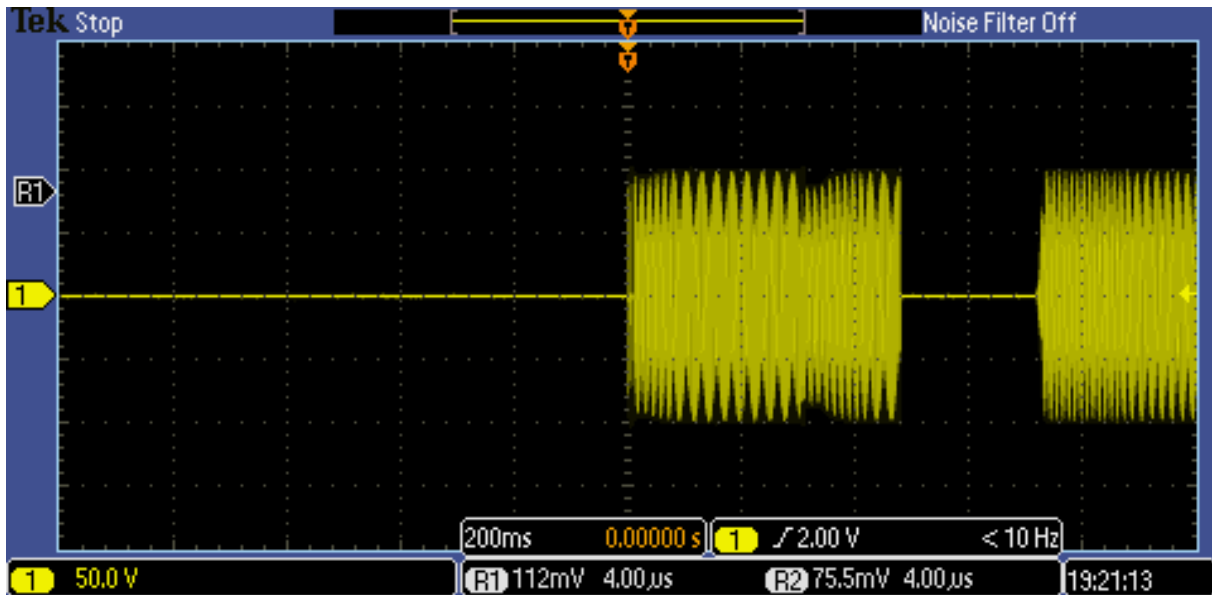

Fig. 16: FT8, Drive 100%



FT8 test, conclusions

We analyzed and tested one of the most preferred digital modes actually very used between ham-community. The measurements carried out did not reveal any presence of voltage spikes.

Maximum output power test.

We tested in FM mode in each band, the maximum output power of the transmitter. Find the results below. The Drive slider in ESDR2.0 was set to 100% in any band.

Fig. 17: main carrier @1.900 MHz, FM, Drive slider 100%

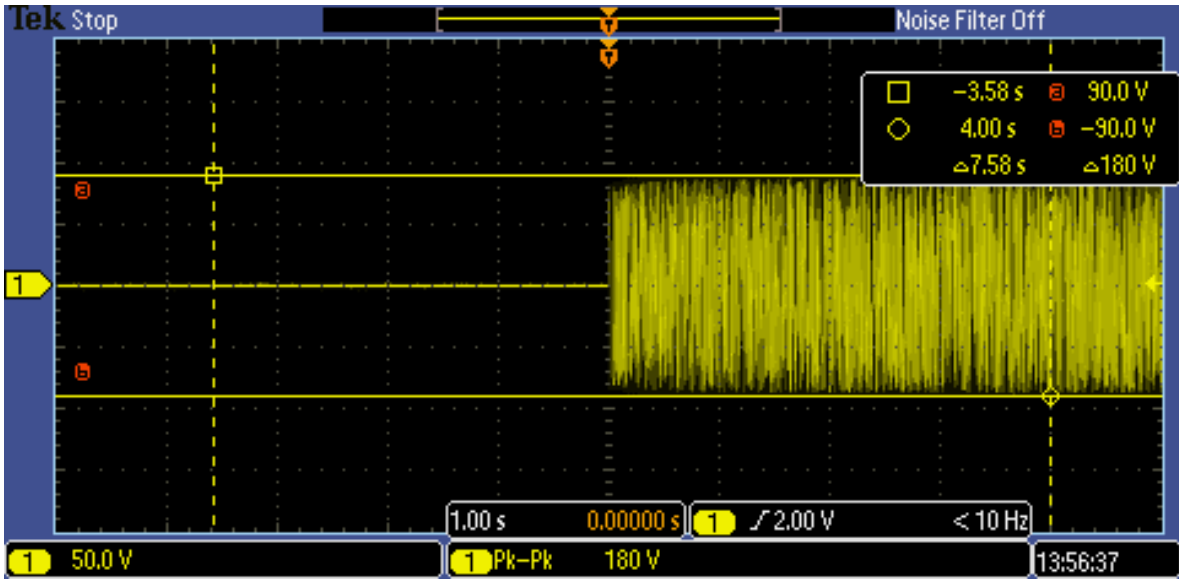

A peak-to-peak value of 180V is measured, equal to approximately 81W of output. Main carrier frequency 1.900 MHz.

Fig. 18: main carrier @3.750 MHz, FM, Drive slider 100%

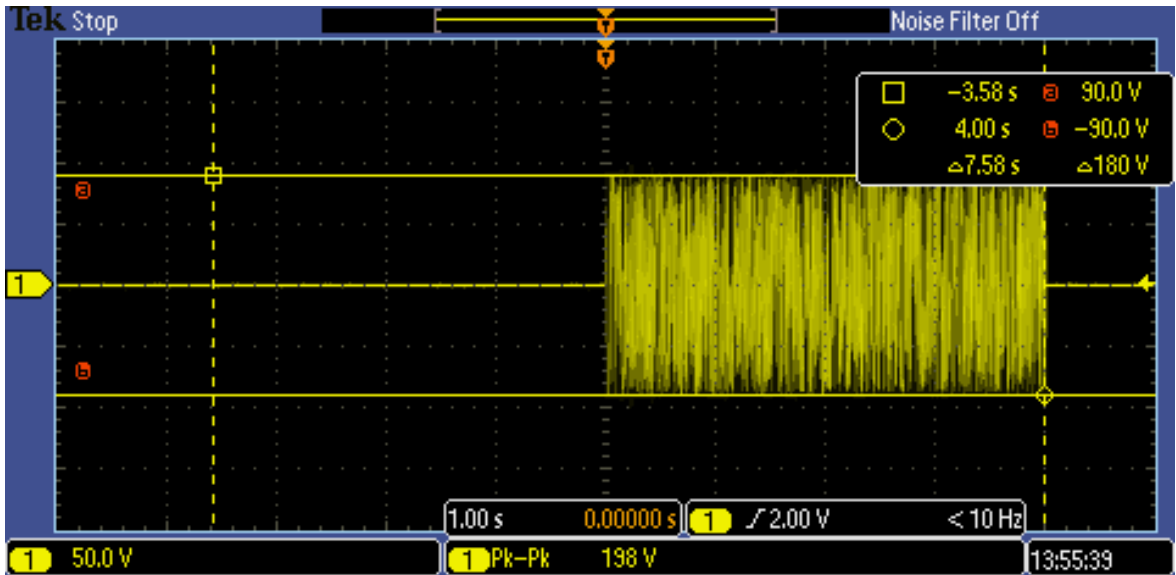

A peak-to-peak value of 198V is measured, equal to approximately 98W of output. Main carrier frequency 3.750 MHz.

Fig. 19: main carrier @7.150 MHz, FM, Drive slider 100%

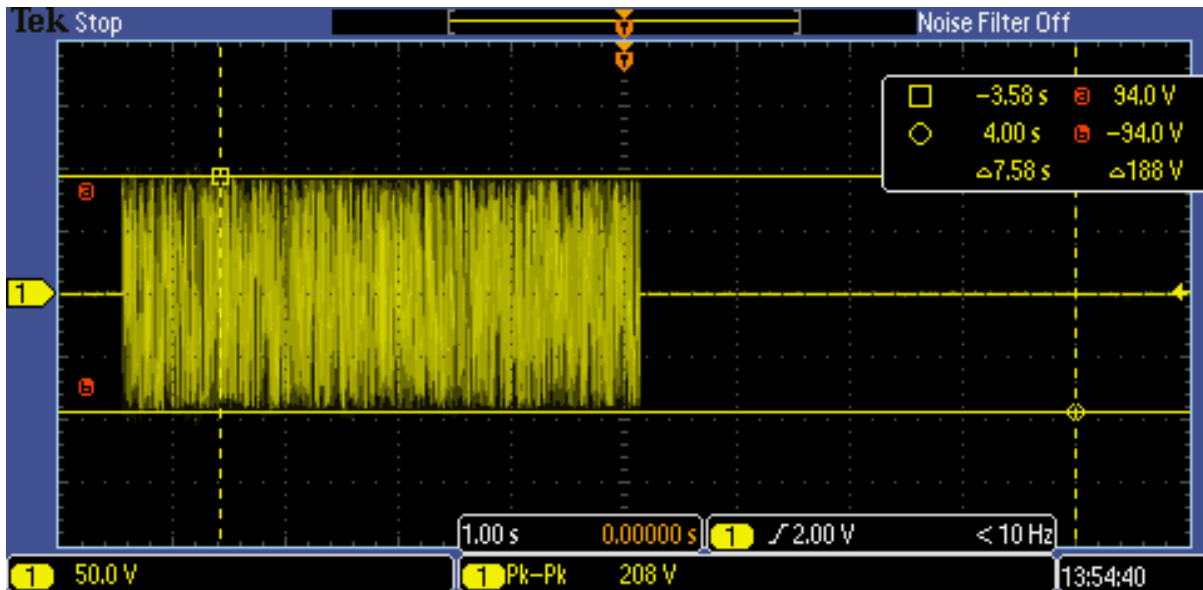

A peak-to-peak value of 208V is measured, equal to approximately 108W of output. Main carrier frequency 7.150 MHz.

Fig. 20: main carrier @10.130 MHz, FM, Drive slider 100%

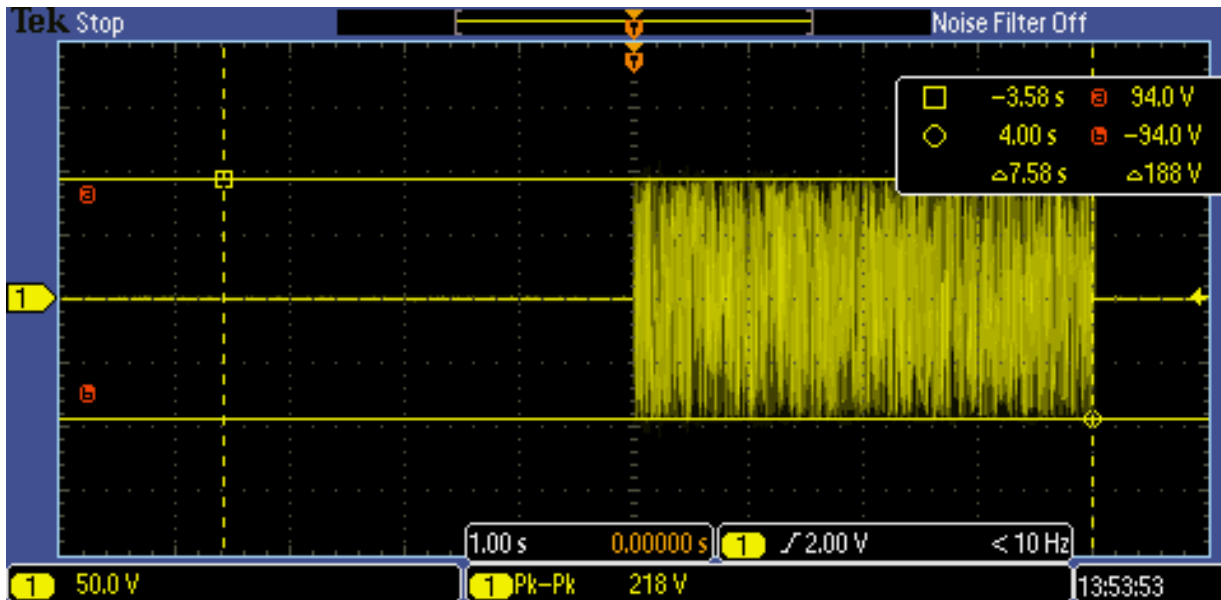

A peak-to-peak value of 218V is measured, equal to approximately 118W of output. Main carrier frequency 7.150 MHz.

Fig. 21: main carrier @14.200 MHz, FM, Drive slider 100%

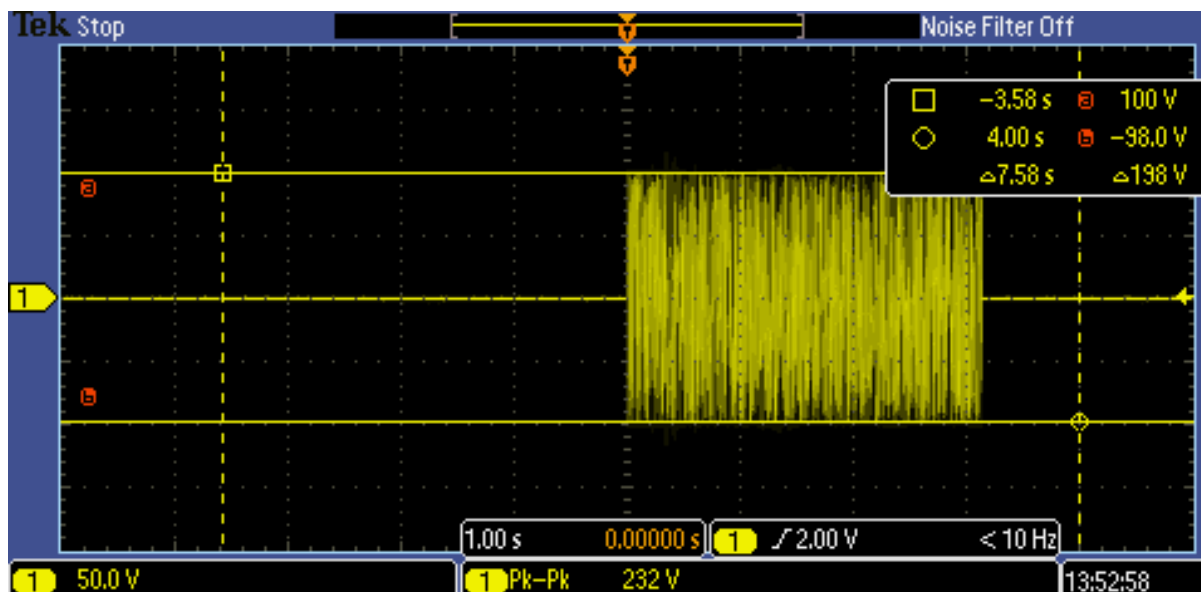

A peak-to-peak value of 232V is measured, equal to approximately 134W of output. Main carrier frequency 14.200 MHz.

Fig. 22: main carrier @18.130 MHz, FM, Drive slider 100%

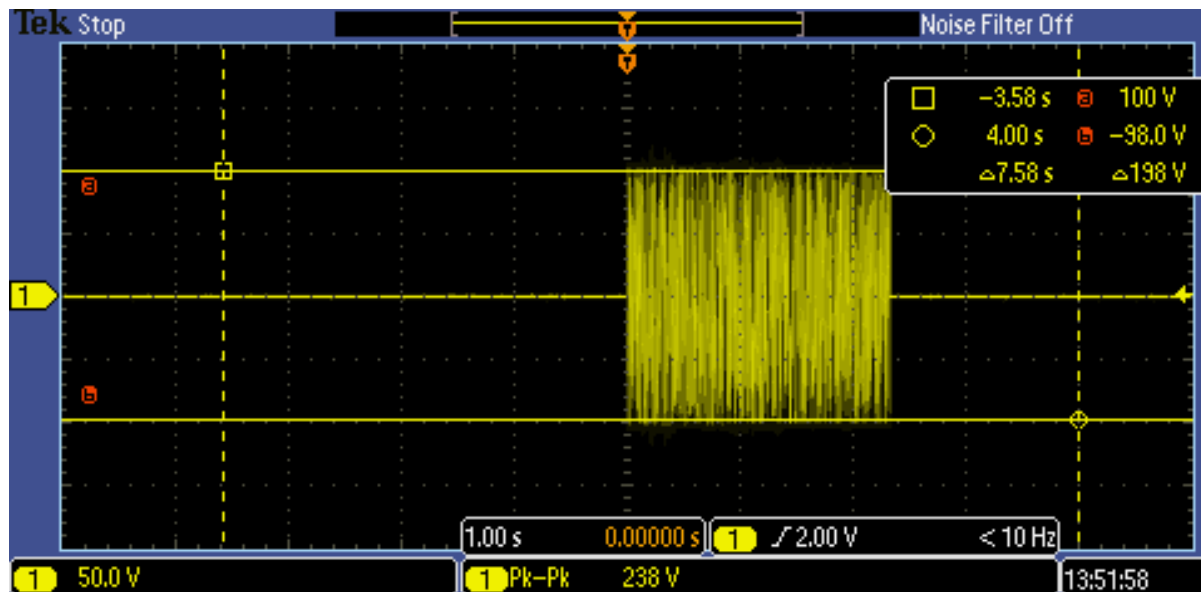

A peak-to-peak value of 238V is measured, equal to approximately 141W of output. Main carrier frequency 18.130 MHz.

Fig. 23: main carrier @21.300 MHz, FM, Drive slider 100%

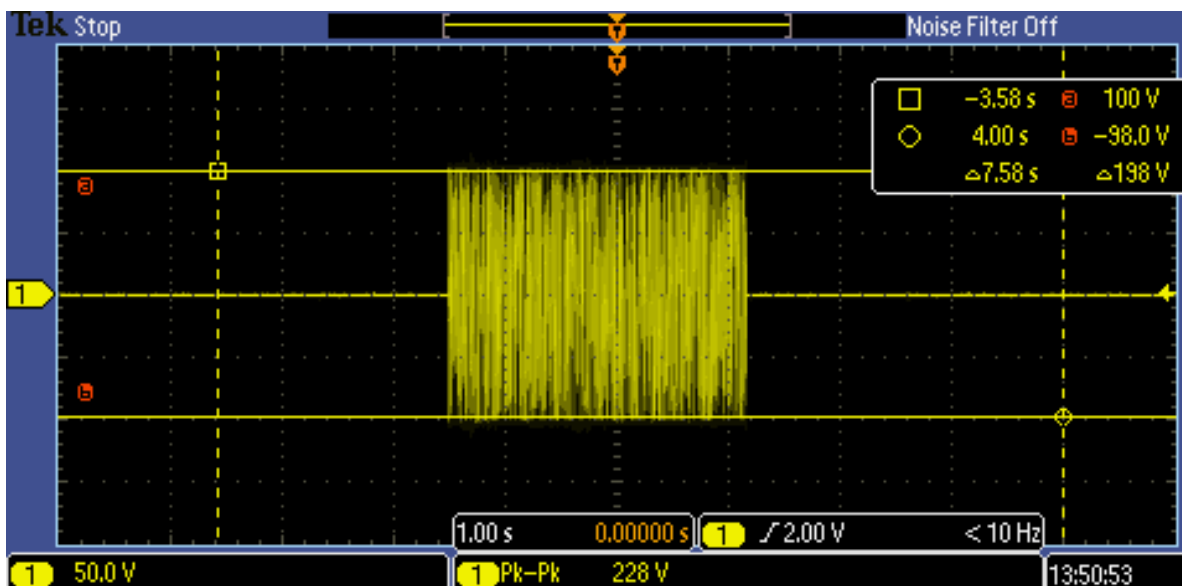

A peak-to-peak value of 228V is measured, equal to approximately 130W of output. Main carrier frequency 21.300 MHz.

Fig. 24: main carrier @24.940 MHz, FM, Drive slider 100%

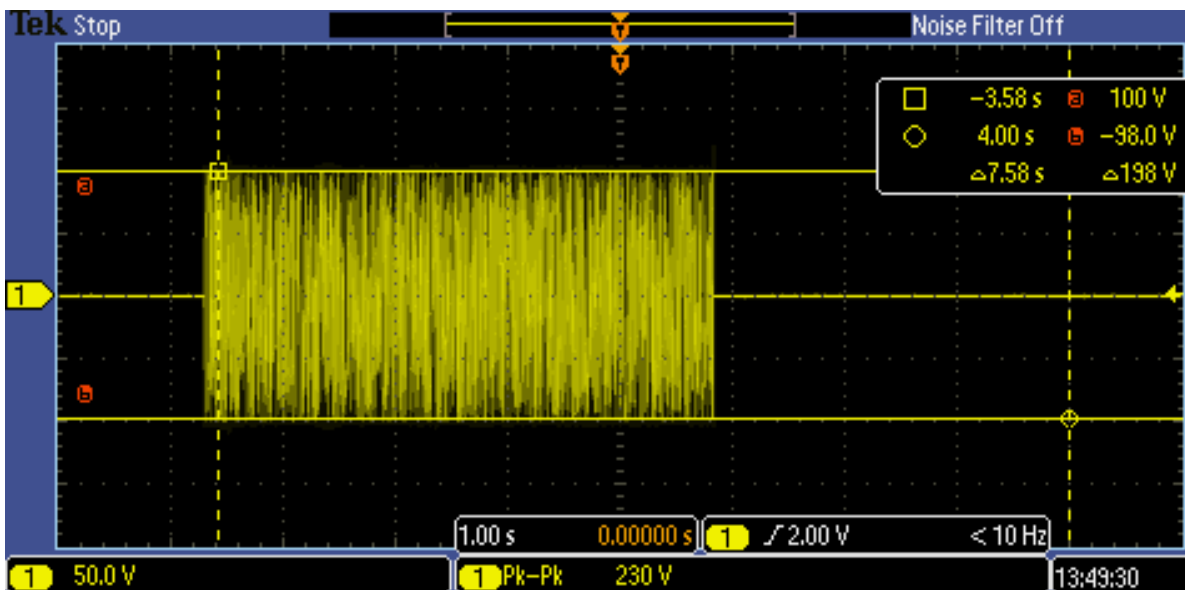

A peak-to-peak value of 230V is measured, equal to approximately 132W of output. Main carrier frequency 21.300 MHz.

Fig. 25: main carrier @28.850 MHz, FM, Drive slider 100%

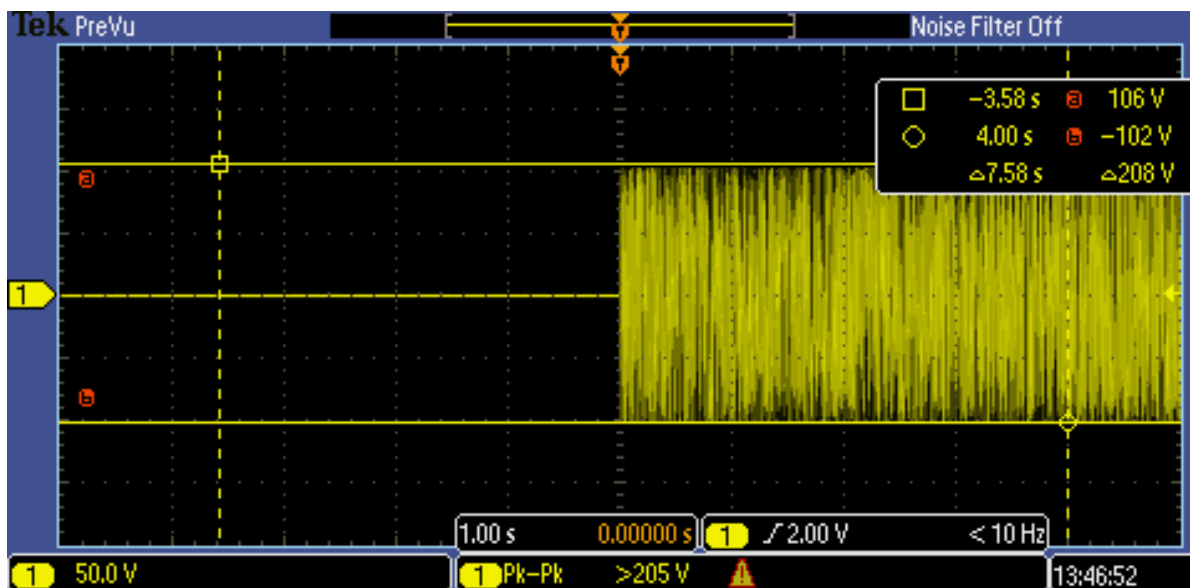

A peak-to-peak value of 208V is measured, equal to approximately 108W of output. Main carrier frequency 28.850 MHz.

Final conclusion

Even if no spikes was revealed, it is strongly recommended to use an external wattmeter to the SunSDR2DX to measure the exact output power of the transmitter; the wattmeter integrated in the ESDR2 software shows values that differ from those measured. **This measurement is very important in order not to overload the amplifiers with the input signal.**

Always be very careful, and use the output power scaling factors in ESDR2 to avoid driving your power amplifiers with excessive power, causing damage.

Reference

- 1) SunSDR2 DX transceiver, <https://eesdr.com/en/products-en/transceivers-en/sunsd2dx-en>
- 2) A power overshoot (spike) analysis on SunSDR2-PRO
<https://iw7dmh.jimdofree.com/sunsd2-pro-pages/a-power-overshot-spike-analysis-on-sunsd2-pro/>
- 3) MFJ-264, Dummy Load, <https://mfjenterprises.com/products/mfj-264>
- 4) Watts <> dBm <> Volts Converter, <https://www.random-science-tools.com/electronics/dBm-Watts-volts.htm>

Disclaimer:

I am not responsible for any damage to people or equipments that may derive from the improper use of transmitters and amplifiers.

Ivan De Cesaris, ivan@iz0jny.it , 21st December 2021.